



## Allentare Mechanical Water Pressure 52mm

Tech Support 1-800-265-1818  
<http://usa.vdo.com>

Instruction Sheet # A2C59506768

Rev 09-2014

### Gauge Installation:

1. Select the desired mounting location of the instrument.
2. Mount the gauge and secure with the VDO Clamp.  
(See page 2 for mounting options and instructions)

### Wiring the Gauge (Illustration A):

1. Route wires from the instrument to:
  - (a) the light switch after the fuse box or user supplied in-line fuse - 1 amp.
  - (b) a good, dedicated ground location.

### Gauge hookup:

1. Route the tube from the gauge to the engine.
2. Push the tubing on to the gauge fitting.
3. Locate and remove the plug in the water cooling jacket on the engine. Replace with proper size male tube fitting and attach the tube.

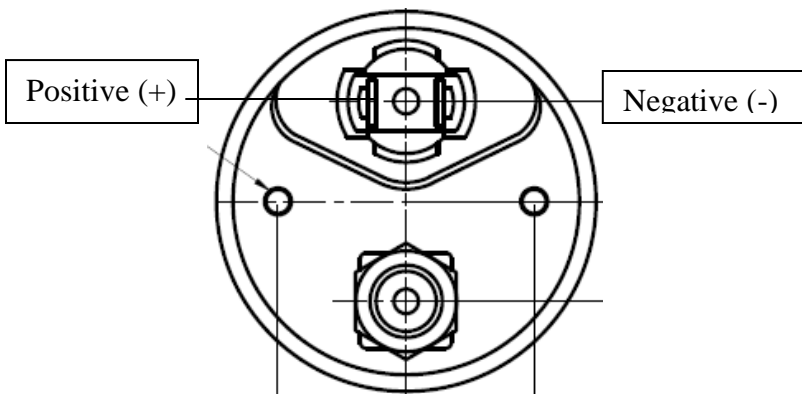

Merchandise warranted against defects in factory workmanship and materials for a period of 24 months after purchase. This warranty applies to the first retail purchaser and covers only those products exposed to normal use or service. Provisions of this warranty shall not apply to a VDO product used for a purpose for which it is not designed, or which has been altered in any way that would be detrimental to the performance or life of the products, or misapplication, misuse, negligence or accident. On any VDO part or VDO product found to be defective after examination by manufacturer, manufacturer will only repair or replace the merchandise through the original selling dealer. Manufacturer assumes no responsibility for diagnosis, removal and/or installation labor, loss of vehicle use, loss of time, inconvenience or any other consequential expenses. The warranties herein are in lieu of any other expressed or implied warranties, including any implied warranty or merchantability of fitness, and any other obligation on the part of manufacturer, or selling dealer.

Read these instructions thoroughly before installation. Do not deviate from assembly or wiring diagram. Always disconnect battery ground before making any electrical connections.

**IMPORTANT:** Mounting dimensions vary for different gauges. Please be certain to follow the instructions for your specific gauge.

Parts List		
<u>Item</u>	<u>Description</u>	<u>Qty</u>
1	52mm Gauge	1
2	Clamp	1
3	Gasket	1
4	Instruction Sheet	1

**DO NOT CRIMP** the tubing closed during routing.

**Do not coil** excess tubing, cut to length.